

## Custom Crate Request

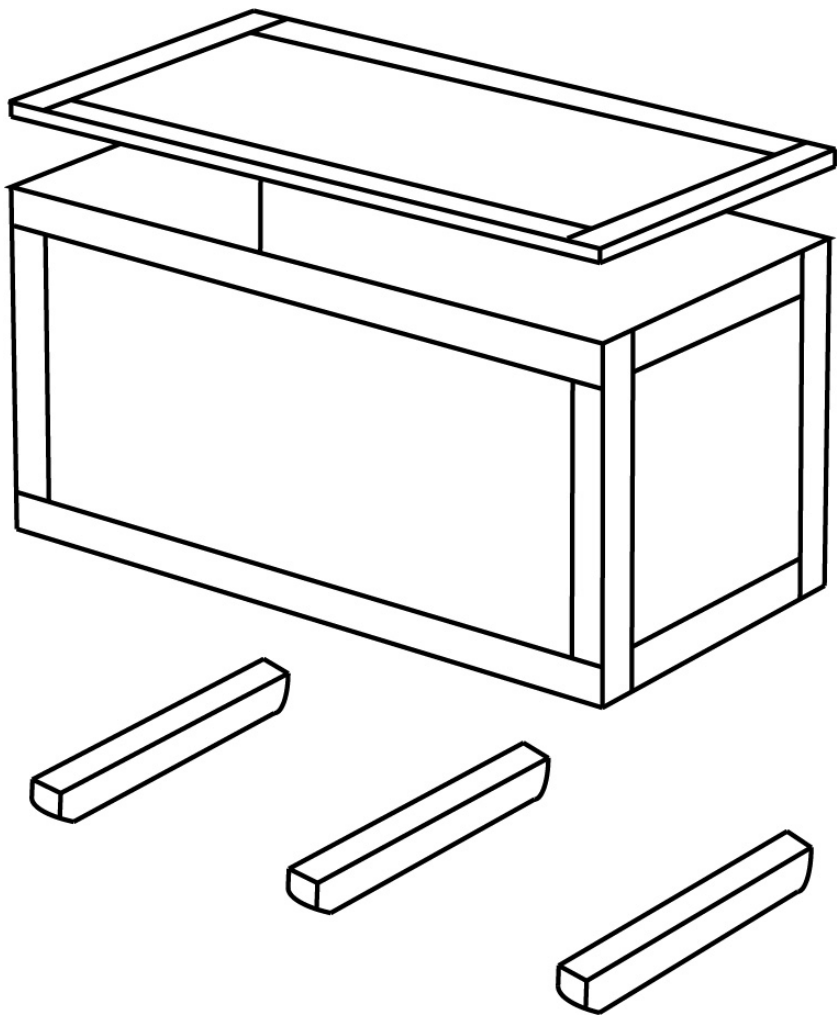

Customer Information
Company:
Name:
Phone:
Email:
Req'd Delivery Date:
Quote Qty:

### Product Information

Product Weight: \_\_\_\_\_ lbs

Brief Product Description:

Product Dimensions:

L\_\_\_\_\_ in.      W\_\_\_\_\_ in.      D\_\_\_\_\_ in.

Foam/Other  
Insert?:

Yes

No

*if yes, please fill out custom insert sheet*

Additional Notes:

Crate Dimensions:

L\_\_\_\_\_ in.

W\_\_\_\_\_ in.

D\_\_\_\_\_ in.

*internal dimensions*

Pallet Runners:

Yes

No

Assembly:

Fully Assembled

Knocked Down

Lid Specs.:

Slip Lid (fits over box with cleats to lock in place)

Attached Lid (facilitates side or end loading)

Loose Lid (removable for loading from top)

Hardware: (click all that apply)

Hinges (attaches loose panel for easy opening)

Paint (added for visuals)

Lifting Ring (allows loose or box to be lifted)

Lifting Handles (used for ease of handling)

Eye Bolts (used for strapping down product)

*we have a solution for that*

**Tolerances U.O.S.**

Tolerances are typically +/- 1/16"