

Special Endmill Request

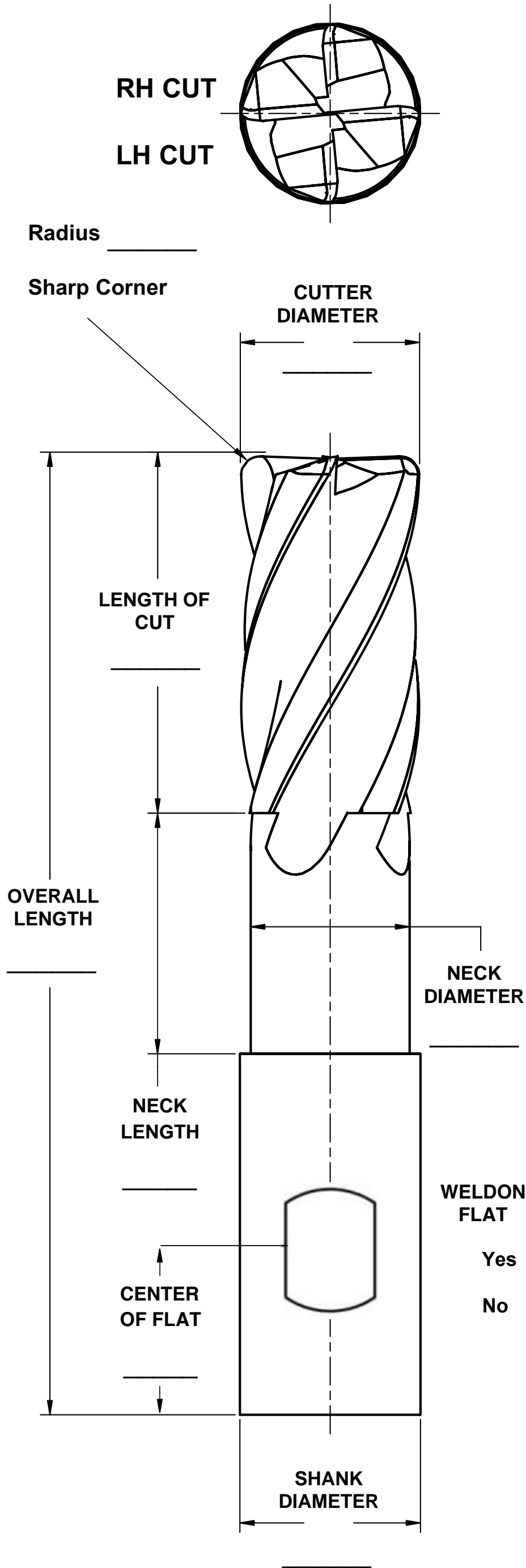

Customer Information
Company: _____
Name: _____
Phone: _____
Email: _____
Req'd Delivery Date: _____
Quote Qty: _____

Machining Information

Workpiece Material: _____

Machine Type: _____

Tooling Information

Inch

Metric

Number of Flutes: _____

Coating on Tool:

No

Yes (AlTiN)

Other

Please specify: _____

Tool Material:

Carbide

HSS

Cobalt

Additional Notes:

Tolerances U.O.S.

.0	+/- .03
.00	+/- .010
.000	+/- .003
.0000	+/- .0005
Frac	+/- 1/32
Angular	+/- 1/2 deg

we have a solution for that